



An Arduino Uno Simulation of Pulse Sensor-Based Heart Rate Monitoring Systems

¹Lawal Mukhtar Ibrahim, ²Mukhtar Ibrahim Bello, ³Musa Dan-azumi Mohammed, ⁴Umar Farouk Musa, ⁵Sadiku Aminu Sani, ⁶Muhammad Ahmad Baballe*

¹Department of Electrical and Electronics Engineering, Altinbas University Istanbul, Turkey.

²Department of Computer Science, School of Technology, Kano State Polytechnic, Nigeria.

³Kano State Institute for Information Technology, Kura, Nigeria.

^{4,5}Department of Architecture Technology, School of Environment Studies Gwarzo, Kano State Polytechnic, Nigeria.

⁶Department of Mechatronics Engineering, Nigerian Defence Academy (NDA), Kaduna, Nigeria.

DOI: [10.5281/zenodo.14028595](https://doi.org/10.5281/zenodo.14028595)

Submission Date: 05 Oct. 2024 | Published Date: 02 Nov. 2024

*Corresponding author: [Muhammad Ahmad Baballe](mailto:muhammad.ahmad.baballe@nada.gov.ng)

Department of Mechatronics Engineering, Nigerian Defence Academy (NDA), Kaduna, Nigeria.

ORCID: [0000-0001-9441-7023](https://orcid.org/0000-0001-9441-7023)

Abstract

Effective heart rate monitoring is crucial for critically ill individuals experiencing organ system failure. Traditional methods include pulse tests and digital heartbeat devices. Cardiac monitoring, particularly auscultation with electronic stethoscopes, enables the early detection of heart disease and failing heart valves. This study has covered in detail the benefits and drawbacks of using the heart rate monitoring sensor. This study examines the use of an Arduino Uno to simulate heart rate monitoring devices based on pulse sensors.

Keywords: Arduino Uno, Heart Failure (HF), Cardiac Monitoring, Heart Rate Sensor, Bluetooth Module.

I. INTRODUCTION

Cardiac monitoring is a vital tool for monitoring individuals with heart issues. One method for identifying heart illness and malfunctioning heart valves early on is auscultation. Using an electronic stethoscope to listen for heart sounds is known as auscultation [10-11]. Blood pressure is a function of the heart's electrical and mechanical activity, which occurs when blood passes through heart valves and into the heart and lungs' chambers. The carotid pulse is used in this study to indicate blood pressure [12] [13] [14]. The carotid pulse records carotid artery pressure signals; the record is done by placing a sensor on the neck and is an alternative to seeing blood pressure signals [15] [14]. This carotid pulse is also useful for a phonocardiograph (PCG) and can help identify a second heart (S2) and its components. Carotid pulse provides information about indications of variations in blood pressure signals in the arteries and the volume of each heartbeat [16] [17]. A carotid pulse can also help a clinician to analyze the differences between normal and abnormal heart conditions (a type of aortic stenosis heart defect). This condition can be done by displaying the heart sound signal (S2) and carotid pulse signals (Dicrotic Notch) simultaneously. Therefore, making a diagnosis is not enough to see the heart signal but also other parameters such as heart sound signals (PCG) and blood pressure signals represented by carotid pulse. In 2013 Vashisth [3] [9]. Agnia Nerlika created a personal computer-based electrocardiography (ECG) tool in 2008, but it only displays ECG signal graphs. In this study, the author used a disposable electrode to collect the ECG signal using standard lead I. The ECG signal was transferred into the computer via serial communication based on an asynchronous interface. In this design, an author needs a long and secure cable to protect from lost data. However, the study was only performed using an ECG simulator or phantom and has not been verified using humans. Another study that related to the cardiac monitor was conducted by Dian Hera et al. They made a personal computer-based phonocardiography (PCG) apparatus. Still, it only displays PCG signal graphs and has a weakness, namely that the signal displayed on the computer unit is not real-time data but data that has been buffered and then displayed. Furthermore, from the weakness of other researchers, Federico et al. developed a personal computer-based cardiac monitor PCG and ECG parameters by simultaneously displaying both signals. Still, there were no carotid pulse parameters [19] [20]. The carotid pulse is essential to monitoring the heart rate. Thus, in 2017, Samsul Anwar made a BPM tool on a computer

unit-based carotid artery via Bluetooth, but the signal produced still contains noise [21] [18] [22]. A signal with high noise will disturb the existence of the original.

II. LITERATURE REVIEW

Heart failure (HF) is a serious, long-term illness. However, it is manageable in spite of the high mortality rate and related expenses. Big data, the internet of things, and artificial intelligence are examples of emerging technologies that have benefits for HF management [25–33]. Using the medical records of HF patients, five machine learning algorithms—deep learning (DL), generalized linear models (GLM), naïve base (NB), random forest (RF), and support vector machines (SVM)—were used to build classifiers to predict HF. The results indicate that machine learning algorithms are effective tools for classifying the medical records of HF patients. GLM and SVM can potentially be utilized together to predict HF with high classification accuracy [7]. This paper presents a systematic review to highlight the use of IoT, IoMT, and machine learning to detect, predict, or monitor cardiovascular disease. We had a final sample of 164 high-impact journal papers, focusing on two categories: cardiovascular disease detection using IoT/IoMT technologies and cardiovascular disease using machine learning techniques. For the first category, we found 82 proposals, while for the second, we found 85 proposals. The research highlights a list of IoT/IoMT technologies, machine learning techniques, datasets, and the most discussed cardiovascular diseases. Neural networks have been popularly used, achieving an accuracy of over 90%, followed by random forest, XGBoost, k-NN, and SVM. Based on the results, we conclude that IoT/IoMT technologies can predict cardiovascular diseases in real time, ensemble techniques obtained one of the best performances in the accuracy metric, and hypertension and arrhythmia were the most discussed diseases. Finally, we identified the lack of public data as one of the main obstacles for machine learning approaches for cardiovascular disease prediction [8]. In this paper, an implementation of an affordable medical technology health monitoring sensor system is developed and demonstrated to measure blood saturation levels (SpO₂), heart rate, and body temperature simultaneously. The embedded system is based on the Arduino platform due to reliability and plug-and-play capability. The proposed pulse oximetry sensor uses spectrophotometry to calculate the ratio of oxygenated hemoglobin to deoxygenated hemoglobin, which is then used to calculate the percentage of oxygenated blood levels. The accuracy of the pulse oximeter is enhanced using light-emitting diodes, driver circuits, and sample and hold circuits, so that a variable baseline can be established for different skin tones, including the finger width where the measurements are undertaken. The embedded sensor system is designed to monitor SpO₂, heart rate, and body temperature and display the obtained results on an LCD. The measured vitals are also transmitted via Bluetooth module to Android mobile and using Wi-Fi module to the internet, forming an internet of things platform for the designed embedded system of sensors. The low-cost embedded sensor system reported in this study can be used to monitor key health parameters of patients in hospitals or at home. The proposed affordable medical technology sensor system can be used as a wearable wireless sensor, which can be used as a plug-and-play sensor with Arduino to monitor human key health parameters. The measured health parameters are compared with a commercially available Choice Med pulse oximeter, and a maximum deviation of 2% is observed, which demonstrates that the proposed sensor device is highly accurate [1]. This article presents the design and implementation of an Internet of Things (IoT)-based remote health monitoring system for the estimation of blood pressure (BP), heart rate (HR), and blood oxygen saturation levels (SpO₂). Our designed sensor can remotely monitor BP, HR, and SpO₂. Our device collects, evaluates, predicts, and reads health data and then stores it on a remote platform named “Think Speak,” which forms an IoT platform with a 0.91 organic light-emitting diodes (OLEDs) screen display for viewing numerical health readings locally. We used a biomedical sensor device with an embedded signal condition unit, and a single photoplethysmography (PPG) signal was employed to derive and measure the PPG signal. A computer-based algorithm was generated, which factored in selected beneficial parameters measured from a single bio-inspired PPG signal. The measured PPG signal was used to estimate the individual user’s BP (both systolic and diastolic values), HR, and SpO₂. An automatic multiscale-based peak (AMBP) detection algorithm was developed to obtain the maximum peak of the PPG signal. Furthermore, the developed sensor was benchmarked against two standard commercially available measurement devices: a Contec ambulatory BP sensor and a Braun pulse oximeter monitor. Our developed sensor is worn as a ring sensor and is interfaced with an Arduino 1010 WIFI MKR for remote health monitoring. Our estimated BP, HR, and SpO₂ values were remotely monitored, and a graphical representation was constructed [2]. This paper outlines the development of an economical Internet of Things (IoT)-based real-time health monitoring system. The prototype integrates a microcontroller and various sensors to monitor essential health parameters, including temperature, heart rate (HR), electrocardiogram (ECG), blood oxygen saturation (SpO₂), and blood pressure (BP). With a focus on enhancing the accessibility of sensor data, diverse access options were implemented using advanced technical methodologies. The collected sensor data was efficiently stored, uploaded to the cloud, and visualized through tools such as HTML, Blynk, PAX-DAQ, and PuTTY, enabling seamless access via mobile devices or laptops. The paper concludes with the presentation of measurement results and an initial analysis of the sensor data, affirming the practicality and effectiveness of the proposed methods [3]. Wearable sensor systems (WSS) have garnered substantial attention as they showcase their versatility not only in the development of automated healthcare systems and shaping smart cities but also in extending their applications into fields such as personalized fitness monitoring and seamless human-computer interaction. Wearable technologies have evolved into more sophisticated forms, significantly improving their capacity to capture multimodal physiological signals from individuals. The recorded physiological signals, including

electroencephalography (EEG), electrocardiogram (ECG), galvanic skin response (GSR), photoplethysmography (PPG), and electromyogram (EMG), contain significant and compelling information about the health conditions of individuals. This information has the potential to contribute to and enhance longevity and subjective well-being, aspects that remain mostly unexplored to date. This review delves into the contemporary landscape of research, aiming to unravel the multifaceted interplay among personality traits, physiological signals, and biomarkers that collectively contribute to active and healthy aging. Specifically, we focus on sensing methods and techniques to identify particular personality traits and their connection with health outcomes. The review also outlines key studies that involve the physiological parameters used for health control and age-related diseases. The work also highlights the various kinds of physiological signals containing different useful, identifiable bioindicators for healthy aging across five personality dimensions. Finally, we address technical challenges observed in wearable sensor systems, encompassing data integration, sample size limitations, and privacy concerns, while also presenting a roadmap for future research directions and opportunities [4]. This work introduces the SMART CARE project that aims to develop an integrated monitoring system consisting of hardware and software components that can make the various phases of managing a patient with chronic heart failure (prevention, diagnosis, therapy, follow-up) more efficient. The paper provides the main information on the project and presents and describes the system architecture of the proposed solution [5]. This paper reviews existing IoT healthcare architectures that utilize wearable devices and subsequently presents a scalable and modular system architecture to leverage emerging technologies to solve identified shortcomings. The defined architecture includes ultrathin, skin-compatible, flexible, high-precision piezoelectric sensors, low-cost communication technologies, on-device intelligence, edge intelligence, and edge computing technologies. To provide development guidelines and define a consistent reference architecture for improved scalable wearable IoT-based critical healthcare architectures, this manuscript outlines the essential functional and non-functional requirements based on deductions from existing architectures and emerging technology trends. The presented system architecture can be applied to many scenarios, including ambient assisted living, where continuous surveillance and issuance of timely warnings can afford independence to the elderly and chronically ill. We conclude that the distribution and modularity of architecture layers, local AI-based elaboration, and data packaging consistency are the more essential functional requirements for critical healthcare application use cases. We also identify fast response time, utility, comfort, and low cost as the essential non-functional requirements for the defined system architecture [6]. Heart disease is a hazardous disease. Even today in Indonesia, the disease ranks first as a cause of death. This study aims to design an electrocardiograph (ECG), phonocardiograph (PCG), and carotid pulse on a personal computer using Delphi7 programming. The contribution of this research is that the carotid signal can be displayed on a personal computer monitor so that it can be viewed simultaneously with ECG and PCG signals. In order to intercept the carotid signal on the carotid artery on the surface of the neck, a piezoelectric sensor is used. In this study, the carotid pulse signal was recorded in the left upper neck area of the carotid artery with the help of a piezoelectric sensor. The primary circuit of the cardiac monitor consists of the non-inverting amplifier, low-pass filter 100 Hz, high-pass filter 0.1 Hz, summing amplifier, and Arduino microcontroller. Carotid Pulse Showed that the correlation between the pattern of the dicrotic notch (the D wave) in the carotid pulse and second heart sound (S2) occurred simultaneously or just before the D wave pulse from the carotid pulse for each respondent. The results of data collection from 10 respondents were measured from the correlation between the dicrotic notch (pattern D) on the carotid pulse and S2 on the phonocardiograph, which occurred just before the dicrotic notch from the carotid pulse. The correlation measurement data obtained from an average of 10 respondents showed that the interval between S2 and dicrotic notch was ± 0.063 s [9]. A pulse rate sensor is utilized in our project to measure heartbeat with the help of fingers. Patient heartbeat needs to be continuously checked. This project uses sensors to measure heart rate. These sensors are connected to the LCD to analyze the conditions of a patient. This module is Arduino-based and uses a microcontroller and sensors to monitor patients heart rate. It supports very low data rates for sensor and medical healthcare applications [23].

III. THE ADVANTAGES OF HEARTBEAT SENSOR

1. First of all, it offers real-time cardiac status monitoring, making early abnormality diagnosis and prompt action possible.
2. The system is low-cost, making it accessible to a wide range of users.
3. Not only is it user-friendly and portable, but it is also convenient for patients and healthcare providers.
4. In the event of an emergency, the system can notify and alert family members or medical professionals.
5. Furthermore, the system is easily integrable with other sensors and technologies, enabling the monitoring of more health metrics and vital signs [24].

IV. DRAWBAKS OF HEARTBEAT MONITORING SENSOR

1. The system's accuracy can vary; according to some research, heart rate readings have an average inaccuracy of 5%.
2. The system relies on wireless technology, which may be susceptible to interference or connectivity issues.
3. Furthermore, the system may require regular calibration and maintenance to ensure accurate and reliable readings.
4. Finally, the system may have limitations in terms of the range and distance over which it can transmit data [24].

V. MATERIALS/METHOD

5.2. Below are the materials used in this research

S/N	Names of components used	Quantity
1	Arduino Uno	1
2	Heartbeat Sensor	1
3	Liquid Crystal Display (LCD)	1
4	Batteries	3
5	Bluetooth Module	1

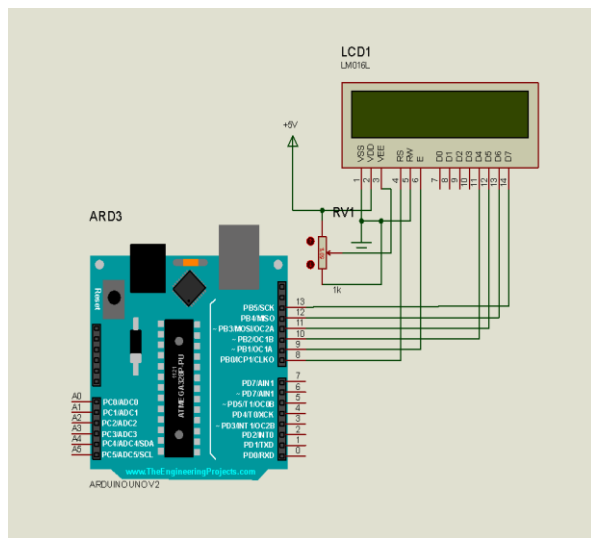

Fig. 1: Connection of the Arduino Uno to Liquid Crystal Display (LCD)

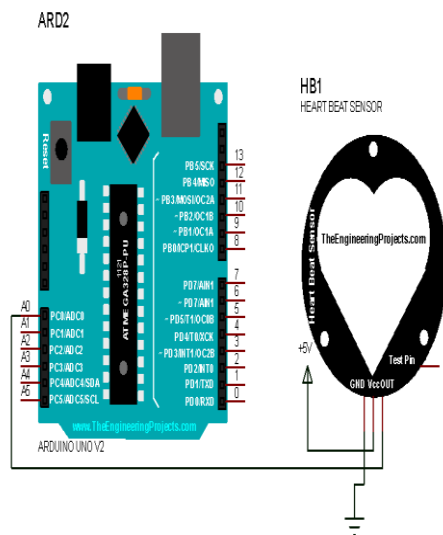

Fig. 2: Connection of the Arduino Uno to the Heartbeat Sensor

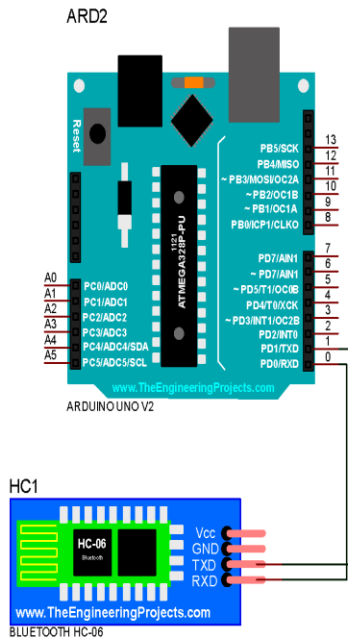

Fig. 3: Connection of the Arduino Uno to the Bluetooth Module

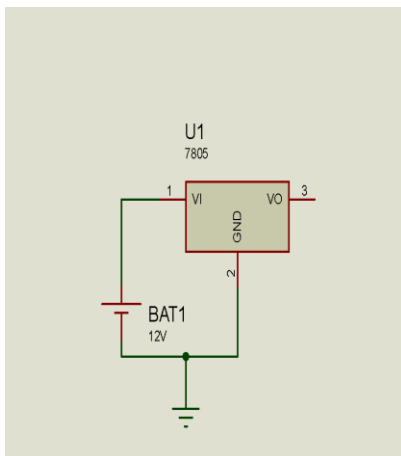

Fig. 4: The Battery configuration

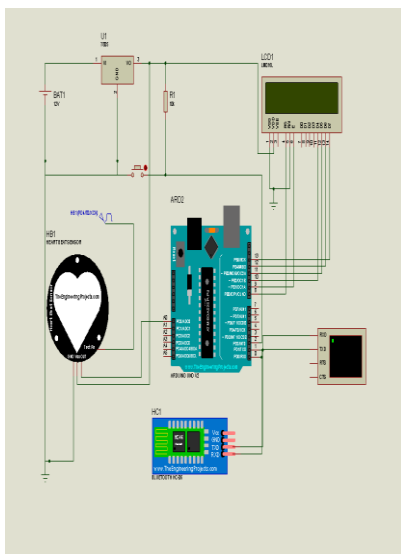

Fig. 5: Complete circuit diagram with the component's connection

5.2 Method

The front of the sensor, with the heart logo, is where you put your finger. You'll also notice a tiny circular opening through which the King Bright's reverse-mounted green LED shines. Just beneath the circular opening is a small ambient light photo sensor (APDS-9008) from Avago. This sensor is similar to the ones used in cell phones, tablets, and laptops to adjust the screen's brightness based on the ambient lighting conditions. On the back of the module are an MCP6001 Op-Amp from Microchip and a few resistors and capacitors that make up the R/C filter network. Additionally, there is a reverse protection diode to prevent damage in the event that the power leads are accidentally reversed. The module requires a DC power supply ranging from 3.3 to 5V and draws less than 4 mA of current. A pulse sensor, like any other optical heart rate sensor, works by shining a green light (~ 550 nm) on the finger and measuring the amount of reflected light with a photosensor. This optical pulse detection technique is known as a Photoplethysmogram. The oxygenated hemoglobin in arterial blood has the property of absorbing green light. The redder the blood (the higher the hemoglobin), the greater the absorption of green light. With each heartbeat, blood is pumped through the finger, causing a change in the amount of reflected light, which in turn produces a waveform at the photosensor's output. As you keep shining light and taking photosensor readings, you quickly begin to obtain a heartbeat pulse reading. This signal from the photosensor is typically small and noisy; therefore, it is passed through an R/C filter network and then amplified with an Op-Amp to create a signal that is significantly larger, cleaner, and easier to detect. The module can be supplied with either 3.3V or 5V. Positive voltage is connected to '+,' while ground is connected to '-.' The third 'S' wire is the analog signal output from the sensor, which will be connected to the Arduino's A0 analog input.

VI. RESULT

Below are the simulation results obtained from the research.

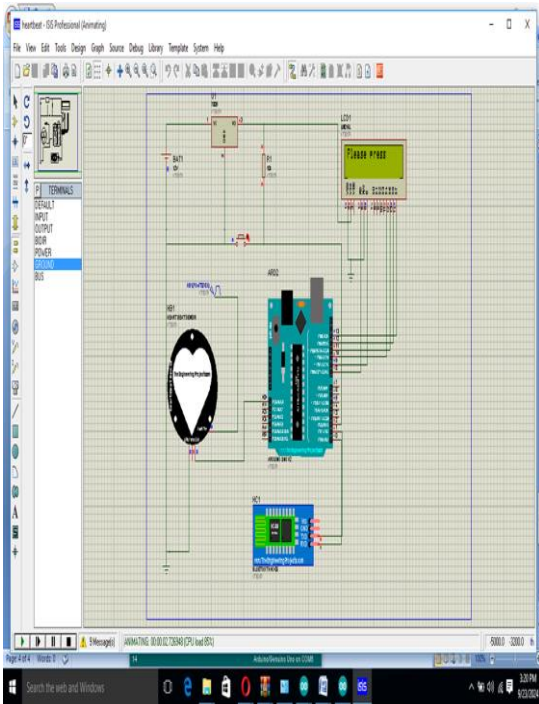

Fig. 6: Simulation result displaying the system is active and functional

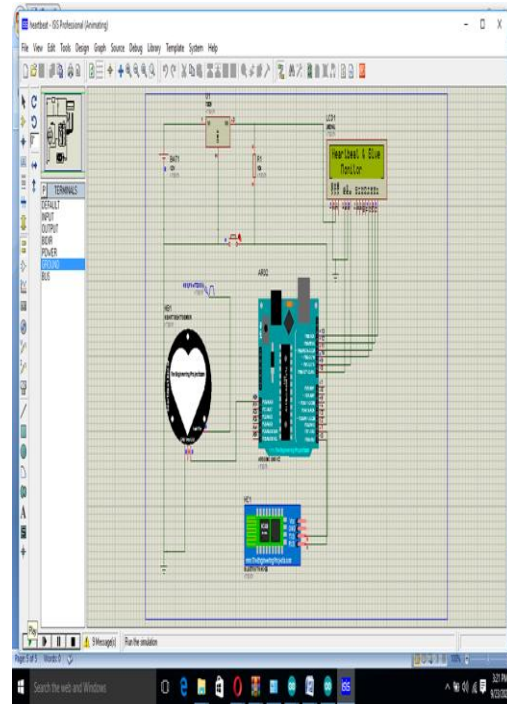

Fig. 7: Result displaying the complete setup of the simulation and the research title

VII. CONCLUSION

To prepare for this investigation, a number of studies on cardiac monitors and blood pressure have been evaluated. We have been shown evidence of their technological prowess and their influence on modern culture [34–35]. There is a detailed explanation of the primary advantages of utilizing wearable technology to track your health.

However, this study also addressed some possible drawbacks. This study discusses the consequences of using the heartbeat sensor [36–37]. This study uses an Arduino Uno to explore the design and simulation of a cardiac monitoring device.

REFERENCES

1. Ali, M.M., Haxha, S., Alam, M.M. et al. "Design of Internet of Things (IoT) and Android Based Low Cost Health Monitoring Embedded System Wearable Sensor for Measuring SpO₂, Heart Rate and Body Temperature Simultaneously", *Wireless Pers Commun* 111, 2449–2463 (2020). <https://doi.org/10.1007/s11277-019-06995-7>.
2. C. Nwibor et al., "Remote Health Monitoring System for the Estimation of Blood Pressure, Heart Rate, and Blood Oxygen Saturation Level," in *IEEE Sensors Journal*, vol. 23, no. 5, pp. 5401-5411, 1 March 1, 2023, doi: 10.1109/JSEN.2023.3235977.
3. T. Wang, A. A. Pileño and E. Monacelli, "How can Sensor Data Accessibility be Enhanced in IoT-Based Health Monitoring Systems?," 2024 IEEE 19th Conference on Industrial Electronics and Applications (ICIEA), Kristiansand, Norway, 2024, pp. 1-6, doi: 10.1109/ICIEA61579.2024.10664742.
4. M. Riaz and R. Gravina, "Wearable Sensor Systems to Detect Biomarkers of Personality Traits for Healthy Aging: A Review," in *IEEE Sensors Journal*, vol. 24, no. 17, pp. 27061-27075, 1 Sept. 1, 2024. doi: 10.1109/JSEN.2024.3429357.
5. I. Sergi et al., "An IoT-aware system for remote monitoring of patients with chronic heart failure," 2023 8th International Conference on Smart and Sustainable Technologies (SpliTech), Split/Bol, Croatia, 2023, pp. 1-5, doi: 10.23919/SpliTech58164.2023.10193338.
6. Shumba, Angela-Tafadzwa, Teodoro Montanaro, Ilaria Sergi, Luca Fachechi, Massimo De Vittorio, and Luigi Patrono. 2022. "Leveraging IoT-Aware Technologies and AI Techniques for Real-Time Critical Healthcare Applications" *Sensors* 22, no. 19: 7675. <https://doi.org/10.3390/s22197675>.
7. S. Eletter, T. Yasmin, G. Elrefae, H. Aliter and A. Elrefae, "Building an Intelligent Telemonitoring System for Heart Failure: The Use of the Internet of Things, Big Data, and Machine Learning," 2020 21st International Arab Conference on Information Technology (ACIT), Giza, Egypt, 2020, pp. 1-5. doi: 10.1109/ACIT50332.2020.9300113.
8. Cuevas-Chávez, Alejandra, Yasmín Hernández, Javier Ortiz-Hernandez, Eduardo Sánchez-Jiménez, Gilberto Ochoa-Ruiz, Joaquín Pérez, and Gabriel González-Serna. 2023. "A Systematic Review of Machine Learning and IoT Applied to the Prediction and Monitoring of Cardiovascular Diseases" *Healthcare* 11, no. 16: 2240. <https://doi.org/10.3390/healthcare11162240>.
9. Wahyu Caesarendra, Triwiyanto Triwiyanto, Her Gumiwang Ariswati, Rizki Masnulula, Nashucha Mutiara Firdaus, M., "Development of Cardiac Monitor Through Carotid Pulse, Phonocardiography and Electrocardiography", *Jurnal Teknokes*, vol. 15, no. 2, pp. 81–87, June. 2022.
10. M. N. Manjunatha, M. Venukumar, E. Raghavendra, M. Varsha, R. Sandeep, and A. A. Audre, "ECG and PPG Data Capture using Novel Three Lead Electrode," in 2017 International Conference on Current Trends in Computer, Electrical, Electronics and Communication (CTCEEC), 2017, pp. 495–498.
11. S. Banpavichit, W. Kongprawechnon, and K. Tungpimolrut, "The 9th International Conference on Computing and Information Technology (IC2IT2013)," *Adv. Intell. Syst. Comput.*, vol. 209, pp. 185–194, 2013.
12. S. Vashisth, M. Khan, R. Vijay, and A. K. Salhan, "Acquisition and Analysis of Human Carotid Pulse Waveforms during Tilt Table Maneuvers," *Int. J. App. Biomed. Engg.*, vol. 6, no. 1, pp. 32–39, 2013.
13. E. A. Suprayitno, I. Sulistyowati, and I. Anshory, "Design Engineering Instrumental Carotid Pulse System in Analitical Heart's Dinamyc with Continuous Wavelet Transform Method," *JEEE-U (Journal Electr. Electron. Eng.,* vol. 1, no. 1, pp. 1–9, 2015.
14. N. F. Hikmah and A. Arifin, "Multimodal Cardiac Signals Analysis (ECG, PCG And Carotid Pulse) For Normal and Abnormal Heart Classification," 2016.
15. C. Li et al., "The relationship between heart-carotid pulse transit time and carotid intima-media thickness in hypertensive patients," *J. Hum. Hypertens.*, vol. 29, no. 11, pp. 663–668, 2015.
16. C. A. D. Leguy, P. Beck, P. Gauger, L. E. J. Beck, and U. Limper, "Carotid Arterial Wall Dynamics During Gravity Changes on Partialg Parabolic Flights," *Microgravity Sci. Technol.*, vol. 26, no. 2, pp. 111–117, 2014.
17. B. Mrozikiewicz-Rakowska, E. Bucior, J. Kania, A. Nowak, M. Chojnowski, and J. Krzymieñ, "Modern alternative or first-line treatment: How to safely use Negative Pressure Wound Therapy in Diabetic Foot Syndrome?," *Negat. Press. Wound Ther. J.*, vol. 2, no. 1, pp. 21–25, 2015.
18. S. Parittotokkaporn, D. De Castro, A. Lowe, and R. Pylypchuk, "Carotid Pulse Wave Analysis: Future Direction of Hemodynamic and Cardiovascular Risk Assessment," *JMA J.*, vol. 4, no. 2, pp. 119–128, 2021.
19. N. Ganapathy, R. Swaminathan, and T. M. Deserno, "Deep Learning on 1-D Biosignals: a Taxonomy-based Survey," pp. 98–109, 2018.
20. F. Gaetani, P. Primiceri, G. A. Zappatore, and P. Visconti, "Hardware design and software development of a motion control and driving system for transradial prosthesis based on a wireless myoelectric armband," *IET Sci. Meas. Technol.*, vol. 13, no. 3, pp. 354–362, 2019.
21. S. Anwar, BPM Pada Carotid Artery Berbasis PC Via Bluetooth. 2017.

22. G. Aditya, M. Oka, A. Pudji, M. Ridha, and E. Yulianto, "Design of Vital Sign Monitor with ECG, BPM, and Respiration Rate Parameters," in Indonesian Journal of Electronics, Electromedical Engineering, and Medical Informatics, vol. 3, no. 1, 2021, pp. 34–38.
23. Manasa S, Rakshitha Y, Sanikakuttappa K, "Heart Rate Monitoring using Arduino", Advances in Intelligent Systems and Technologies, pp. 43-47, 2023, Doi: https://doi.org/10.53759/aist/978-9914-9946-1-2_8.
24. <https://typeset.io/questions/what-are-the-advantages-and-disadvantages-of-using-an-ljddug5yye>.
25. M.A. Baballe, S. H. Ayagi, & U. F. Musa. (2023). Using artificial intelligence (AI) technology in the health sector has several goals. Global Journal of Research in Engineering & Computer Sciences, 3(5), 31–35. <https://doi.org/10.5281/zenodo.10048487>.
26. Abdussalam G., M. A. Baballe, & M. I. Bello. (2023). Applying AI in the Healthcare Sector: Difficulties. Global Journal of Research in Engineering & Computer Sciences, 3(6), 34–38. <https://doi.org/10.5281/zenodo.10182386>.
27. M. A. Baballe, Amanatu K., & Khadija A. B. (2023). "Wearable Connected Devices to Track the Body's Vital Signs", In Global Journal of Research in Engineering & Computer Sciences, Vol. 3, Number 6, pp. 43–47, 2023, <https://doi.org/10.5281/zenodo.10232311>.
28. Haruna G. R., Aminu A.U., N. A. Sulaiman, & M. A. Baballe. (2024). Key Advantages of using Wearable Technology to Track your Health. In Global Journal of Research in Engineering & Computer Sciences (Vol. 4, Number 1, pp. 1–5). <https://doi.org/10.5281/zenodo.10463350>.
29. D.K Garba, & M.A Baballe. (2024). Possible Drawbacks to take into Account while Utilizing Wearable Tracking Devices. In Global Journal of Research in Engineering & Computer Sciences (Vol. 4, Number 2, pp. 6–11). <https://doi.org/10.5281/zenodo.10810759>.
30. Muhammad H. A., Iswanto S, Muhammad A. B., Mukhtar I., "Artificial Intellegent algorithms for Tumor Disease Detection: systematic Literature Review," Sunan Kalijaga of Journal Physics, vol. 5, no. 2, pp. 81 - 94, 2023.
31. M. A. Baballe, A. L. Musa, M. A. Sadiq, I. Idris Giwa, U. s. Farouk, Aminu Ya'u. "Temperature Detection System implementation", Global Journal of Research in Medical Sciences, vol. 2, no. 5, pp. 92–97, 2022, <https://doi.org/10.5281/zenodo.7126185>.
32. Muhammad A. B., Mukhtar I. B., "A Study on the Impact and Challenges of Temperature Detection System" Global Journal of Research in Engineering & Computer Sciences, vol. 1, no. 2, pp. 22-26, 2021.
33. Isa A.I., & Muhammad A. B. (2024). Step-by-Step Guide to Building Wearable Health Devices. In Global Journal of Research in Engineering & Computer Sciences (Vol. 4, Number 5, pp. 52–59). <https://doi.org/10.5281/zenodo.13759291>.
34. Isa A. I. et al., "Infrared Ship Segmentation based on Weakly-supervised and Semi-supervised Learning", IEEE ACCESS, DOI 10.1109/ACCESS.2024.3448301.
35. Isa A. I., Muhammad A. B. "Bidirectional People Counters as a Catalyst for Smart Cities in the Technological Singularity Era", Journal of Emerging Technologies and Innovative Research (JETIR), Volume 11, Issue 10, October 2024, www.jetir.org.
36. Isa A. I., Muhammad A. B., "Heartbeat Sensors: Revolutionizing Cardiovascular Monitoring in the 4IR Era", Journal of Emerging Technologies and Innovative Research (JETIR), October 2024, Volume 11, Issue 10, pp. 164-168, www.jetir.org.
37. Lawal M. I., Mukhtar I. B., Auwal B. I., A. A. Musa, Muhammad A. B. "The Limitations of Pulse SensorBased Heart Rate Monitoring Systems", Global Journal of Research in Engineering & Computer Sciences, Vol. 4, No. 5, Pp. 125– 129, <https://doi.org/10.5281/zenodo.14003493>, 2024.

CITATION

Lawal M. I., Mukhtar I. B., Musa DA M., Umar F. M., Sadiku A. S., & Muhammad A. B. (2024, November 2). An Arduino Uno Simulation of Pulse Sensor-Based Heart Rate Monitoring Systems. In Global Journal of Research in Engineering & Computer Sciences. <https://doi.org/10.5281/zenodo.14028595>