



IoT Traffic Light Display with Emergency Vehicle Management Control System using Wi-Fi

Auwal Usman¹, Auwal Balarabe Ishaq², Ilham Auwal Abdullahi³, Toheeb Kazeem Usman⁴, Hauwa'u Gambo Ishaq⁵, Abdussalam Saminu Abubakar⁶, *Muhammad Ahmad Baballe⁷

^{1,2,3,4,5,6}Department of Electrical Electronics Technology, Kano State Polytechnic, Nigeria, School of Technology.

⁷Department of Mechatronics Engineering, Nigerian Defence Academy, (N.D.A), Kaduna, Nigeria.

DOI: [10.5281/zenodo.13682796](https://doi.org/10.5281/zenodo.13682796)

Submission Date: 26 July 2024 | Published Date: 04 Sept. 2024

*Corresponding author: [Muhammad Ahmad Baballe](#)

Department of Mechatronics Engineering, Nigerian Defence Academy, (N.D.A), Kaduna, Nigeria.

ORCID: [0000-0001-9441-7023](https://orcid.org/0000-0001-9441-7023)

Abstract

In this research, batteries are used to power the whole system, and if it goes down, you can also charge them. There is also a switch on the system that is used to power it ON/OFF. In this project, the four lanes of traffic are named Lane A, Lane B, Lane C, and Lane D. There is a wireless system that is used to control the four lanes in case you decide not to use the control button on the system. With the help of the ESP32 used in the project, you can connect the system using a WIFI connection to enable you to control the whole system either with your smart phone or your personal computer. The buttons are also labeled A, B, C, and D. Also on the wireless system, it is labeled A, B, C, and D, indicating the four lanes of the project. If there is an emergency in lane D and lane A is the one that is working or giving permission to go, you can use either the control switch from the system or the wireless control system to give lane D permission to go. If the cars in the lane, which is D, have passed, then they will automatically go back to the lane in which they are operating, which is lane A. If all the cars have finished passing in lane A, they will then go to lane B, lane C, and lane D and return to lane A again.

Keywords: ESP32, LEDs, LCD, Arduinos, Radio Frequency (RF), Batteries.

I. INTRODUCTION

In order to manage conflicting traffic flows, traffic lights—also referred to as traffic lamps or traffic signals—are signaling devices placed at road intersections, pedestrian crossings, and other sites. Due to their inability to adjust to changing road conditions, traditional traffic signal systems, which operate on set cycles, can be a major cause of traffic congestion. Because they make it take longer for people to get where they're going, traffic bottlenecks are bad for both drivers and other road users. Ambulances and police cars are examples of emergency vehicles that could be seriously endangered by this delay. Using dynamic traffic lights—whose functioning changes depending on the traffic conditions at the intersection is one important way to alleviate traffic congestion at intersections. Since there aren't many scholars in the literature interested in finding solutions to emergency vehicle traffic jam problems, this paper's contribution is the introduction of a revolutionary traffic signal system operation strategy. Two algorithms make up the new strategy: a pure operation mode and a hybrid operation mode. The goal of these operation modes is to shorten the time emergency vehicles must wait at junctions. They make the assumption that an Internet of Things (IoT)-based smart infrastructure system exists that can recognize the arrival of emergency vehicles at a crossroads. The traffic signal operation is changed from fixed cycle mode to dynamic mode by the smart infrastructure system. In order to shorten the time that emergency vehicles must wait at junctions, the dynamic mode controls the traffic signals. The suggested algorithms are simulated in the study, which also emphasizes their benefits. We contrasted our method with the conventional traffic light system and the Wen algorithm found in the literature in order to assess the effectiveness of the new strategy. According to our evaluation study, the suggested algorithms performed better in various traffic circumstances than both the old system and the Wen approach [10]. The traffic light system is controlled by numerous studies. A portion of these techniques included hardware, such as logic circuits and controllers, and were static. These systems don't consider the flow of traffic when

opening and closing the traffic light; instead, they rely mostly on a static, continuous time. To forecast the quantity of automobiles or the state of the traffic jam in each direction, several techniques were created [1]. An introduction to the use of fuzzy logic for traffic light control is provided by Study [2]. In this study, the number of automobiles, the length of the queue, and the width of the road are the criteria used by the researchers to manage the cars as a prioritized queue. The green lights that indicated an empty wait were eliminated during the construction of the fuzzy system. When compared to standard light control systems, the outcome was superior. Researchers discuss the approaches utilized in traffic light system control in-depth in the study [3]. TST and TSC were the primary scopes of many of the searches. While some searches rely on a single parameter, others rely on a set of parameters. The traffic light condition, the length of each light, the required shade of green, the manner in which cars are waiting, the calibration between these cars, and several other significant characteristics are the primary parameters that these systems use. More than 77% of all queries, according to the search, involve the use of simulation tools. Green time, cycle length, phase sequence, change interval, and offset were the primary timing constants. An interview regarding the development of a smart traffic signal system by artificial intelligence is provided in Study [4]. Whether the car weighs more or less than eighty tons is a major factor in this system's operation. This study makes use of Google Earth traffic data; longer travel times are associated with higher traffic intensities. There was an emergency, and cameras were deployed. A software program for modeling logic simulation was used to assess the suggested system. This technology was able to raise the speed of cars to 55% and decrease the number of cars in a given amount of time to 55%. reducing by 29% the number of automobiles that need to wait and by 38% the amount of time that drivers must wait to cross junctions. Researchers attempt to address the issue of junctions passing on 4-way highways in the study [2]. This study considers vehicle and autonomous vehicle communication in addition to standard characteristics. Sensors, computation, and future car predictions were used to detect cars. According to research, establishing traffic as a network can help reduce traffic issues and provide effective control over traffic signals. Reinforcement training was employed by researchers to manage traffic signals in study [4]. Every study under this scope requires at least two intersections. Natural language processing is used in this study to provide the best answer. This investigation found that more than 160 articles used RL approaches to produce the greatest results. The traffic signal systems were controlled using a variety of techniques, including deep learning and machine learning. The primary benefit of the fuzzy logic approach is its speed in comparison to neural networks, which have a large processing overhead and might not operate instantly. Using historical data, neural networks attempt to forecast the number of automobiles. Although the image processing system can provide real-time data for fuzzy logic to process. The concept made it possible for the system to function in real time, displaying changes in the number of automobiles, the traffic light's response to each variation in the car's number, and the movement of the street directions. Similar to this, the image processing system adds value to the system, particularly in cities with heavy traffic, which can also reduce the likelihood of accidents and delays in time. This system can be designed to treat ambulances as a third fuzzy set, with the requirement that they open on the street instantly at the top priority, a medium priority with fire engines and police cars, and a lowest priority with other vehicles [5]. Traffic light control systems are used for particular lanes or crossings in metropolitan areas, while fixed cycle traffic lights are usually used to regulate traffic on the roads. Additionally, improper installation can lengthen the time it takes for traffic to clear junctions and result in excessively long wait times for crossing traffic, which can strand emergency vehicles at intersections. By lowering energy consumption and traffic delay, adaptive signal timing management is a technology that can enhance network-wide traffic operations and is more computationally feasible than existing fixed-cycle signal control systems. Despite the existence of specialized adaptive control systems, emergency vehicles cannot be contacted, which is a critical component of smart cities. This issue led to the creation of a unique framework called Emergency Vehicle Adaptive Traffic Lights (EVATL) for smart cities. EVATL combines emergency vehicle communication with an adaptive traffic light mode to improve traffic signal performance and decrease total traffic delay. EVATL uses GPS and the Internet of Things (IoT) to locate emergency vehicles. It interfaces with traffic lights and uses YOLOv8 to operate adaptively based on vehicle density at the traffic signal. Thus, the main objective of the suggested EVATL is to incorporate adaptive traffic signals for smart cities and prioritize an emergency vehicle at the same time. By building several scenarios for an adaptive traffic light and emergency vehicle communication, a graphical user interface (GUI) is created to assess the suggested model. When examining the simulation results of the suggested model EVATL, it is evident that the prompt identification of an emergency vehicle at a predetermined distance significantly reduces the wait time of cars at a traffic signal [6]. This work presents a smart traffic management system that makes use of the Internet of Things (IoT) [17, 22] to help authorities plan more effectively and handle a range of traffic management difficulties. An algorithm is used to efficiently handle various traffic circumstances, and a hybrid strategy—a blend of centralized and decentralized methods—is used to optimize road traffic flow. To do this, the system uses data on traffic density from cameras, sensors, and other devices to modify traffic signals. An alternative artificial intelligence-based technique is used to predict future traffic density in order to lessen traffic congestion. Furthermore, RFIDs [12, 13, 20] are used to prioritize emergency vehicles, such as ambulances and fire brigade vehicles, during a traffic gridlock. This system's component for detecting a fire on the road also includes smoke sensors [19, 21]. To demonstrate the value of the suggested traffic management system, a prototype is developed that not only facilitates better traffic flow but also establishes a connection between neighboring rescue departments via a centralized server. It also gathers useful information that is displayed graphically, which may benefit the government in the future when designing roads [7]. The population growth and rising car ownership in developing

countries like India have led to an increase in traffic congestion and accidents [14, 15, 16, 18]. However, a smart traffic control system that uses RFID sensors can lessen these issues by recognizing congested areas and improving traffic flow. This method also enables emergency vehicles to get at their destination more swiftly by granting them priority. The real-time data provided by RFID sensors can also be advantageous to drivers as it can reduce idle time and save them money. Using this information, alternate routes can be suggested to drivers, allowing them to avoid congested areas and reduce the amount of time they spend trapped in traffic. This not only improves traffic flow but also helps reduce pollutants and fuel consumption, making the environment cleaner and greener. Emerging countries like India can employ a smart traffic control system with RFID sensors to regulate the increasing traffic flow and reduce traffic accidents. In rising nations like India, an RFID-based smart traffic control system has the potential to greatly enhance the welfare of road users, the economy, and the environment [8]. Using the minimal distance triggering mechanism, the dynamic navigation system and smart traffic light assess the movement of emergency vehicles. In the modern world, traffic congestion is a big problem that causes a lot of chaos and losses to both the economy and people's quality of life. The issues associated with traffic become much more significant when we consider emergency vehicles, including ambulances. In order to reduce travel time, ambulances nowadays frequently drive past intersections carelessly (for example, by speeding past a T junction without considering the risk factors), which raises the possibility that the ambulance will be involved in an accident. The traffic signals in the existing system follow a predefined sequence of green lights; that is, the lights don't turn green until the signal's predetermined timing limit is reached. This system's inability to account for emergency vehicles lowers the system's overall efficiency. Through our project, this static system is altered to become efficient and real-time (i.e., dynamic). First, Proteus DS is used to simulate the primary hardware, which will be a retrofit table system for the existing static time-based traffic system. Second, an Android Studios app is created to control the traffic signal. Thirdly, the desired cloud platform (AWS, Google Cloud, or Microsoft Azure) will be used to construct a web application. In [9], [11]. In this research, a simple representation of a traffic light controller system is designed and constructed. We need three LEDs of red, yellow, and green colors at each intersection. The intersection is divided into four lanes: Lane 1, Lane 2, Lane 3, and Lane 4. All the LEDs are connected to the Arduino NANO's digital I/O pins (L1 – A5, A4, A3: L2 A0, A1, A2: L3 D10, D11, D12: L4 D0, A6A7) through respective current limiting resistors of 4.7Ω . The IR sensor is interfaced with the Arduino (Rx), which takes the counting, which is sent to the Arduino and displayed via the LCD (8-D8, 9-D9, 4-D4, 5-D5, 6-D6, 7-D7). The Power is regulated from 12v to 5v through Lm7805(25v 220uF) Capacitor IN 4007Diode Thus, $VDD = 5v$ [25].

II. MATERIAL AND METHODS

Table I: Below are the materials used in this research

S/N	Names of components	Number used
1	LEDs	12
2	Liquid crystal display	1
3	Arduino Nano	1
4	ESP32	1
5	Battery	6
6	Voltage Regulator	1
7	Resistors	12
8	Capacitors	5
9	Arduino Uno	1

2.2. Method

Since the research is a traffic light controller, the circuit consists of many LEDs (12, as a matter of fact), as we are implementing traffic lights at a 4-way intersection. The research is a simple representation of a traffic light controller, and hence no other extra components are used. We need three LEDs of red, yellow, and green colors at each intersection. The intersection is divided into four lanes: Lane A, Lane B, Lane C, and Lane D. All the LEDs are connected to the Arduino NANO's digital I/O pins (L1 – A5, A4, A3: L2 A0, A1, A2: L3 D10, D11, D12: L4 D0, A6A7) through respective current limiting resistors of 4.7Ω . The ESP32 used in the research is used to control the whole system either with your smart phone or personal computer using Wi-Fi connections. Also, the wireless radio frequency connector is used to control the system in case you decided not to make use of the control the is mounted on the system.

III. RESULTS

The results obtained during the construction phase, after necessary troubleshooting, were satisfactory. The system was able to respond to its operation.

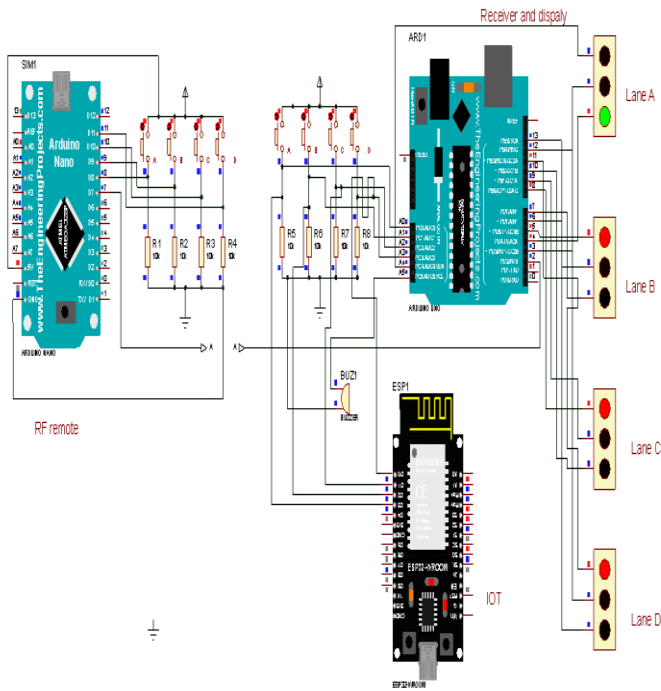

Figure 1: Configuration of the whole simulation system

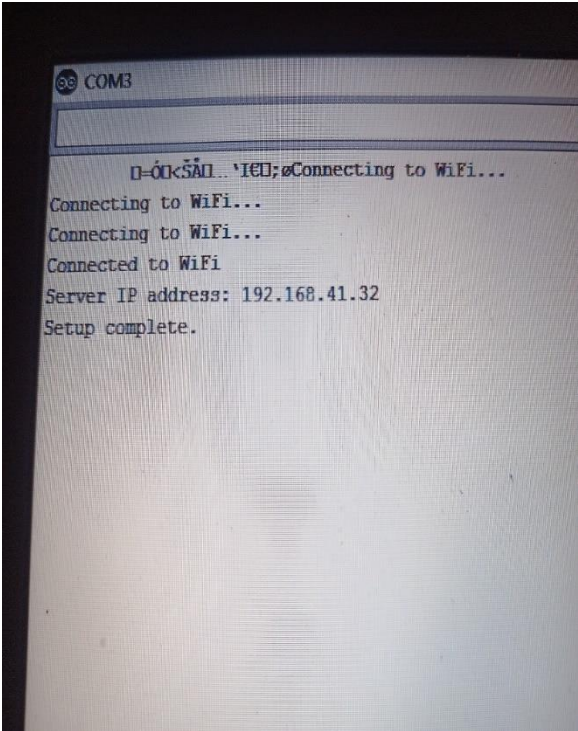

Figure 2(a): Connecting the system with Wi-Fi

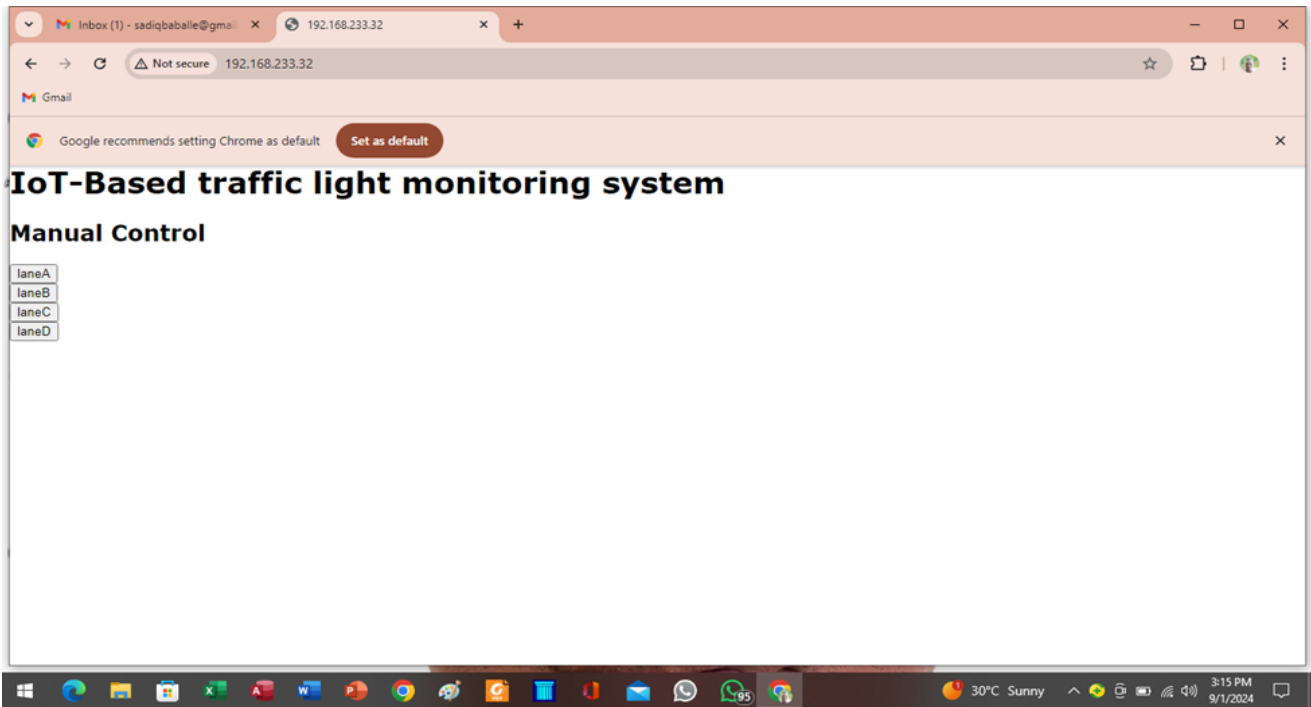

Figure 2(b): The system is connected with the Wi-Fi

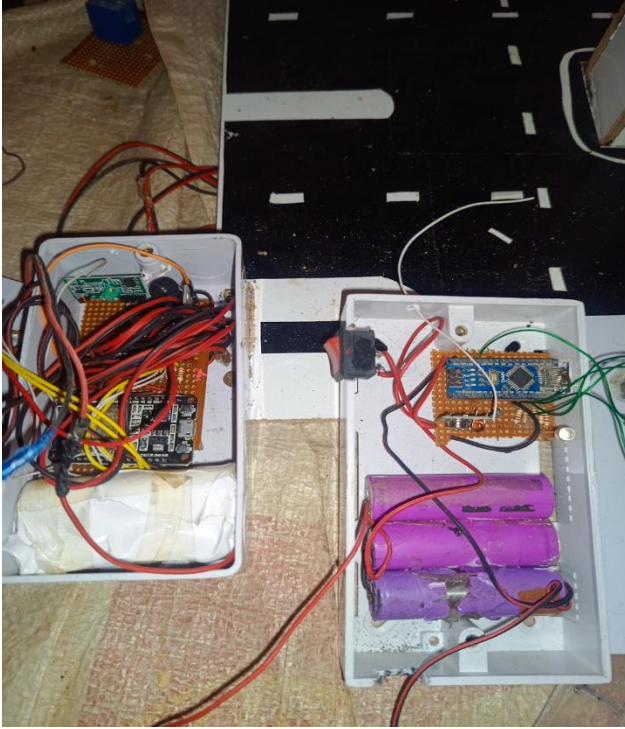

Figure 3: The internal circuitry of the two controllers

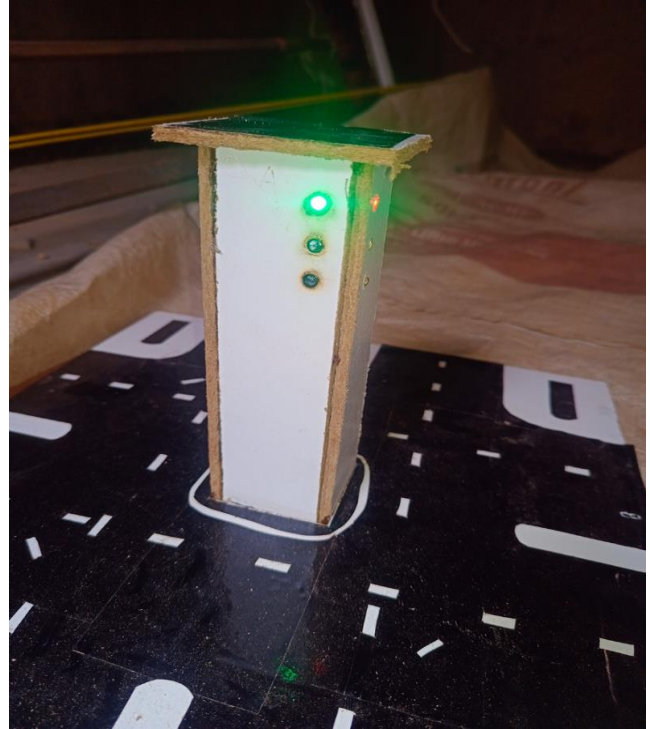

Figure 4: The Implemented system showing Lane A is active

IV. CONCLUSION

For this study, a large number of articles were read, and their technological innovations were noted. The simulation result of the system has been assessed and found to operate effectively; implementing the technology will reduce traffic bottlenecks and maybe save lives [23]. This research has validated the four lanes' efficient operation as well as the design of the complete system [24]. In this study, a traffic lighting system with an Arduino-based car counting system was built. Nevertheless, the system satisfies our design goals and has shown to be efficient. For example, the gadget should be appropriately placed at the side of a road intersection so that cars traveling in both lanes can see the traffic signals. Because of this, there are far less opportunities for traffic accidents, bottlenecks, and holdups on this circuit. Since no previous research has ever combined radio frequency (RF) and the ESP32, the ESP32 employed in this study has demonstrated a significant improvement.

REFERENCES

1. D.Patel, & Y.Rohilla, "Infrared sensor based self-adaptive traffic signal system using arduino board". In 2020 12th International Conference on Computational Intelligence and Communication Networks (CICN) (pp. 175-181) IEEE., 2020, September, doi: 10.1109/cicn49253.2020.9242560
2. M.jha, SH. shukla," design of fuzzy logic traffic controller for isolated intersections with emergency vehicle priority system using matlab simulation" <https://arxiv.org/ftp/arxiv/papers/1405/1405.0936.pdf>.
3. A.Nigam., M.Chaturvedi, & S.Srivastava, "An Empirical Study on Parameters Affecting Traffic Stream Variables Under Rainy Conditions". In 2022 14th International Conference on COMMunication Systems & NET work S (COMSNETS) (pp. 818-823). IEEE. 2022, January.
4. S. komsiyah, E. desvania, "traffic lights analysis and simulation using fuzzy inference system of mamdani on threesignaled intersections"., science direct journal, volume 179, 2021, pages 268-280, <https://doi.org/10.1016/j.procs.2021.01.006>.
5. R. T. Gdeeb, "A Controlling Traffic Light system using Fuzzy logic", Journal of Al-Qadisiyah for Computer Science and Mathematics Vol. 15(3) 2023, pp Comp. 141–153.
6. A. Dodia, et al., "EVATL: A novel framework for emergency vehicle communication with adaptive traffic lights for smart cities", IET Smart Cities, 2023, 1–15, wileyonlinelibrary.com/journal/smc2.
7. J. D. Reddy, et, al., "AI Based Smart Traffic Management", International Journal of Scientific Research in Engineering and Management (IJSREM), Volume 07, Issue 07, 2023.

8. D. Adhwanth, et al., "Rfid Based Traffic Control System for Emergency Vehicle", International Journal of Engineering Technology and Management Sciences, Issue 3, Volume No.7, May - June - 2023, DOI:10.46647/ijetms.2023.v07i03.034.
9. N. Raghu, et al., "Smart Traffic Light and Dynamic Navigational System for Emergency Vehicles", 2022, at: <https://www.researchgate.net/publication/364049958>.
10. Y. Tashtoush, M. Al-refai, G. Al-refai, N. Zaghal, D. Darweesh, O. Darwish, "Dynamic Traffic Light System to Reduce the Waiting Time of Emergency Vehicles at Intersections within IoT Environment", International Journal of Computers Communications & Control Online, ISSN 1841-9844, ISSN-L 1841-9836, Volume 17, Issue 3, June, 2022, <https://doi.org/10.15837/ijccc.2022.3.4482>.
11. M. A. Baballe, U. F. Musa, Y. A. Ohiani, & Mustapha B. A. (2023). Faults and Solutions for Smart Traffic Lights. Global Journal of Research in Engineering & Computer Sciences, 3(5), 36–40. <https://doi.org/10.5281/zenodo.10050434>.
12. M. B. Ahmad, F. A. Nababa," A comparative study on radio frequency identification system and its various applications", International Journal of Advances in Applied Sciences (IJAAS) Vol. 10, No. 4, December 2021, pp. 392~398 ISSN: 2252-8814, DOI: 10.11591/ijaas.v10.i4.pp392-398.
13. M A. Baballe," A Study on the Components used in RFID System and its Challenges", Global Journal of Research in Engineering & Computer Sciences Volume 01| Issue 01 | Sep-Oct | 2021 Journal homepage: <https://gjrppublication.com/journals/>.
14. A. S. Bari, M. A. Falalu, M. A. Umar, Y. Y. Sulaiman, A. M. Gamble, & M. A. Baballe. (2022). Accident Detection and Alerting Systems: A Review. Global Journal of Research in Engineering & Computer Sciences, 2(4), 24–29. <https://doi.org/10.5281/zenodo.7063008>.
15. M.A. Baballe, Aminu Ya'ui, S.F. Ibrahim, Abdulmuhamin M., & N.K. Mustapha. (2023). Accident Detection System with GPS, GSM, and Buzzer. Global Journal of Research in Engineering & Computer Sciences, 3(1), 8–14. <https://doi.org/10.5281/zenodo.7655016>.
16. M. A. Baballe, A. S. Bari, A. L. Musa, N. K. Mustapha, U. H. Hussain, D. Bello, & A. A. Umar. (2022). Car Tracking System: Pros and Cons. Global Journal of Research in Humanities & Cultural Studies, 2(5), 188–191. <https://doi.org/10.5281/zenodo.7102272>.
17. Z. Abdulkadir, A. Ibrahim, A. Muhammad, *M. A. Baballe, S. A. Sani," Contribution of the IoT to the Security System", Global Journal of Research in Engineering & Computer Sciences ISSN: 2583-2727 (Online) Volume 03| Issue 04 | July-Aug. | 2023 Journal homepage: <https://gjrppublication.com/gjrecs/>.
18. Abdulrahman Y.A., M. I. Bello, S.A. Sani, A. Ibrahim, & M. A. Baballe. (2023). Fire Extinguisher types and Applications. Global Journal of Research in Engineering & Computer Sciences, 3(4), 45–50. <https://doi.org/10.5281/zenodo.8286527>.
19. Amina I., Sadiku A. S., Muntaka D., Abdulmuhamin M., & M. A. Baballe. (2023). Modern Alarm Sensors for Security Systems. Global Journal of Research in Engineering & Computer Sciences, 3(4), 11–15. <https://doi.org/10.5281/zenodo.8193716>.
20. M. B. Ahmad, F. A. Nababa, "The need of using a Radio Frequency Identification (RFID) System", International Journal of New Computer Architectures and their Applications (IJNCAA) 11(2): 22-29 The Society of Digital Information and Wireless Communications.
21. M. B. Ahmad, "The Various Types of sensors used in the Security Alarm system", International Journal of New Computer Architectures and their Applications (IJNCAA) 9(2): 50-59 The Society of Digital Information and Wireless Communications.
22. M. Çavaş, M. B. Ahmad, "A Review Advancement of Security Alarm System using Internet of Things (IoT)", International Journal of New Computer Architectures and their Applications (IJNCAA) 9(2): 38-49 The Society of Digital Information and Wireless Communications.
23. D.K Garba, & M. A Baballe. (2024). Design and Simulation of a Traffic Light Management System. In Global Journal of Research in Engineering & Computer Sciences (Vol. 4, Number 2, pp. 1–5). <https://doi.org/10.5281/zenodo.10810739>.
24. Danladi K. G, Aminu H., Nuhu A. S, & Muhammad A. B. (2024). Building Traffic Signal Control Systems using Arduino Nano. In Global Journal of Research in Engineering & Computer Sciences (Vol. 4, Number 2, pp. 132–139). <https://doi.org/10.5281/zenodo.11050649>.
25. Omoya J.P., Abubakar S.I., Abubakar M. Musa, & Muhammad A. B. (2024). A Dynamic Traffic Management System: Construction and Simulation. In Global Journal of Research in Engineering & Computer Sciences (Number 4, pp. 131–136). <https://doi.org/10.5281/zenodo.13340801>.

CITATION

Muhammad A. B, Auwal U., Auwal B.I., Ilham A.A., Toheeb K.U., Hauwa'u G. I., & Abdussalam S.A. (2024). IoT Traffic Light Display with Emergency Vehicle Management Control System using Wi-Fi. In Global Journal of Research in Engineering & Computer Sciences (Vol. 4, Number 5, pp. 1–6). <https://doi.org/10.5281/zenodo.13682796>



Global Journal of Research in Engineering & Computer Sciences

Assets of Publishing with Us

- **Immediate, unrestricted online access**
- **Peer Review Process**
- **Author's Retain Copyright**
- **DOI for all articles**